

## Sun alarm

# Renewable energy blog 5

[www.tts-shopping.com](http://www.tts-shopping.com)

Follow this step-by-step guide on how to build a sun alarm.

Associated resources:  
Renewable energy lesson plan  
PowerPoint 5 – Sun alarm  
Workbook 5 – Sun alarm

### **You will need:**

#### **Parts included in class kit**

- 1 solar panel and motor mounted on stand (used in blog 4)
- Offcuts of polystyrene foam sheet
- 1 buzzer
- 1 LED (light emitting diode)
- 2 crocodile leads
- 1 propeller

#### **Other parts, tools and consumables**

- Ruler
- Felt tip pen
- Large scissors
- Low melt glue gun
- Pencil



### **Step 1**

Disconnect the motor from the solar panel as follows. Unscrew the two nuts from the studs on the back of the solar panel where the motor is connected. Remove the washers and slide off the motor contacts. Refit the washers and nuts so you don't lose them.



### **Step 2**

Gently bend the legs of the LED apart a little. Connect one crocodile lead from the positive (+) terminal on the solar panel where the motor was connected to the long leg of the LED. Connect the second crocodile lead from the negative (-) terminal where the motor was connected to the short LED leg. Make sure the metal ends of the crocodile clips are not touching one another. Hold the solar panel facing the sun and check the LED lights up.

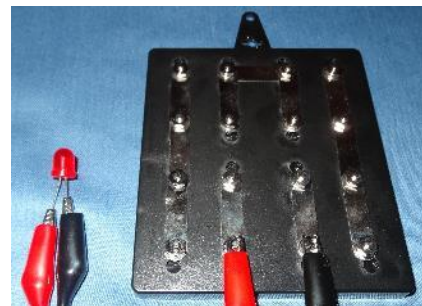

### **Step 3**

Disconnect the crocodile clip from the long leg of the LED and connect it to the metal end of the red wire to the buzzer. Disconnect the crocodile clip from the short leg of the LED to the black wire from the buzzer. Hold the solar panel facing the sun and check the buzzer sounds.



**Step 4**

Get both the LED to light up and the buzzer to come on at the same time as follows. Connect the crocodile clip attached to the red wire to the buzzer onto both the (metal end of the) red buzzer wire and the LED long leg simultaneously. Connect the crocodile clip attached to the black wire to the buzzer onto both the (metal end of the) black buzzer wire and the LED short leg simultaneously. The buzzer and LED are now connected in parallel. Hold the solar panel facing the sun and check the buzzer sounds and the LED lights up.

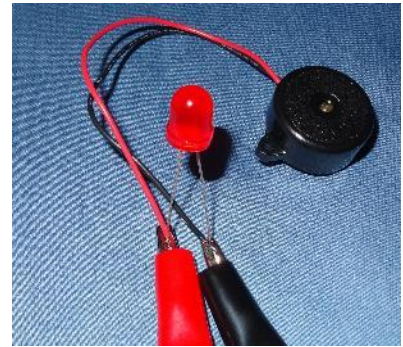
**Step 5**

Make a stand to mount the buzzer and LED. An example of the parts needed to make the stand is shown here. You can draw them on the polystyrene foam sheet with the felt tip pen and ruler. You can make the hole for the LED with the pencil and then push the nose of the LED into it from behind. Don't make the hole too big – the LED should fit tightly. You can start the hole for the buzzer with the pencil and then cut it out with the scissors. Again, don't make the hole too big – the buzzer should fit tightly. Cut out the parts with the scissors and glue them together.

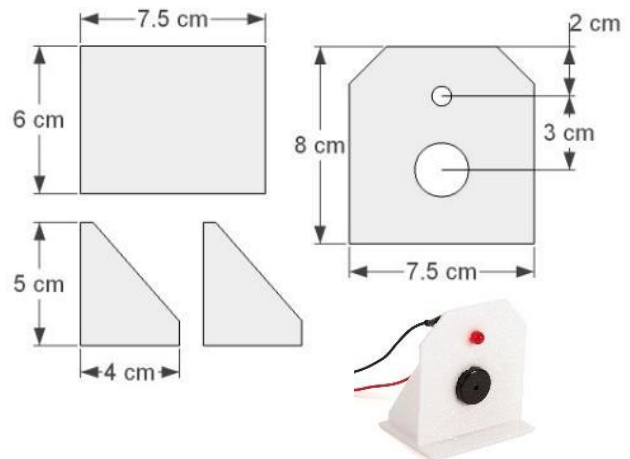
**Step 6**

Carefully peel off the motor stand from the base and replace it with your new stand for the buzzer and LED. Fit the buzzer and LED, connect them in parallel to the solar panel (as per step 4). Place the solar panel back on its mount and try out the sun alarm. You can now use your alarm to remind you to put on your sunscreen or to put the washing out on the line! Can you think of any other uses for a sun alarm?

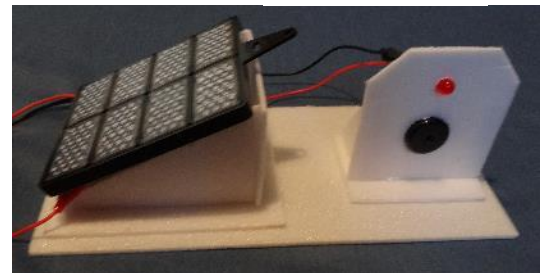
**Step 7**

Try using wind power instead of solar power to make the buzzer sound. Remove the motor pulley from the motor and fit the propeller. Use the two crocodile leads to connect from the motor contacts to the buzzer. Make sure metal ends of the crocodile clips aren't touching one another. Ask someone to hold the buzzer to their ear (or if you have really good lung capacity then you can hold it to your own ear). Blow very hard on the propeller to get it to rotate as fast as possible, and see if you can get the buzzer to sound. If you can't then swap over the crocodile clips attached to the motor contacts and try again. The buzzer only works when connected one way round.

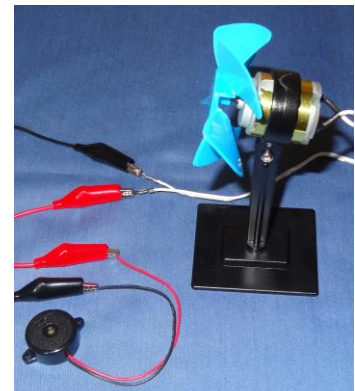
**Step 8**

If you can get the buzzer to sound then you can try using wind power to get the LED to light up. Disconnect the crocodile clip attached to the buzzer red wire and attach it to the long leg of the LED. Disconnect the crocodile clip attached to the buzzer black wire and attach it to the short leg of the LED. Blow the propeller very hard and see if you can get the LED to glow.

