

Electric boat

Renewable energy blog 3

www.tts-shopping.com

Follow this step-by-step guide on how to build a solar powered electric boat.

Associated resources:
Renewable energy lesson plan
PowerPoint 3 – Electric boat
Workbook 3 – Electric boat

You will need:

Parts included in class kit

- 1 motor mounted on stand (completed in blog 1)
- 1 solar panel (completed in blog 1)
- 1 propeller
- 2 foam sheets
- 4 pompoms (2 large and 2 small)

Other parts, tools and consumables

- Ruler
- Felt tip pen
- Cylindrical pencil
- Large scissors
- Low melt glue gun
- Water tray or shallow plastic box with about 3 cm of water in



Step 1

If the motor pulley is still fitted to the motor (as in blog 2) then remove it and store it safely. Hold the back of the motor shaft with your thumb and push the propeller onto the front of the motor shaft. If your motor is disconnected from the solar panel (as in blog 2) then remove the nuts on the studs shown on the back of the solar panel, slide the connectors over the studs and re-fit the nuts. Loosen the nut on the motor stand and turn the motor so that the shaft is facing horizontally. Re-tighten the nut.

Step 2

Hold the solar panel facing the sun and check the propeller spins. Feel which way the air is blowing – the fan should be blowing air away from the motor. If it isn't then remove the two nuts and washers holding the motor contacts onto the solar panel, swap over the motor contacts then put back the washers and nuts. Check the propeller is now blowing air the correct way.

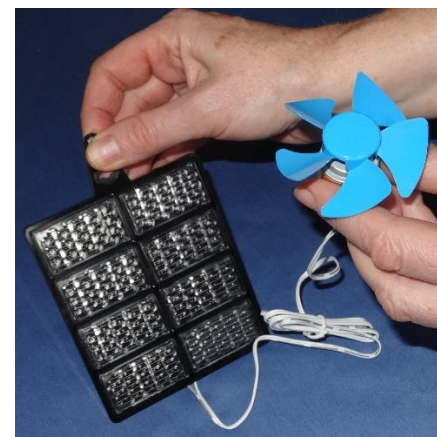
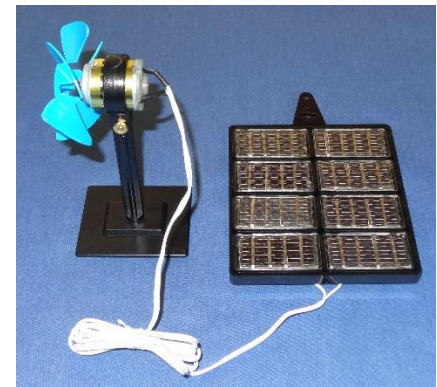
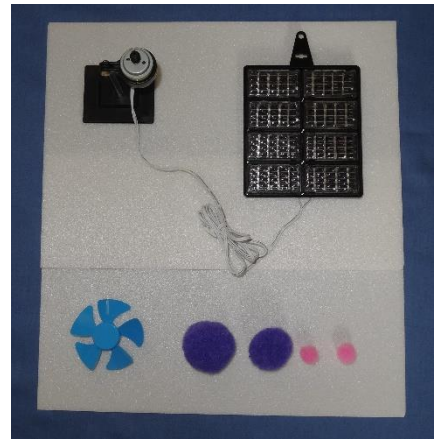

Step 3

Use the ruler, felt tip pen and scissors to mark and cut out the shape shown here from the polystyrene foam sheet. Use this shape as a template and cut out two more of these shapes. Glue the three shapes together in a stack to make a boat. The solar panel is quite heavy, so it is recommended to use a triple stack of foam to support the weight.

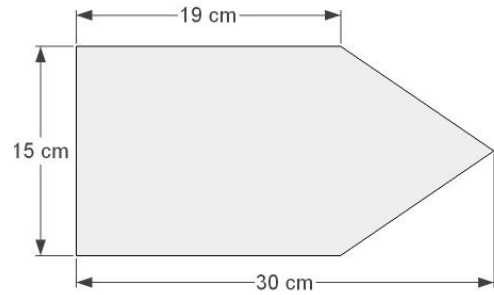

Step 4

Cut two strips of polystyrene foam 2 cm x 19 cm, trim them a little to make a more streamlined shape and glue them to the sides of the stack as shown. This is to help keep the boat travelling in a straight line.

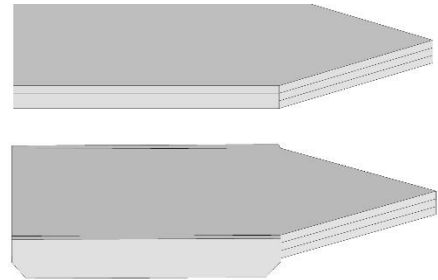

Step 5

Cut out the parts to make a stand from the remaining polystyrene foam sheet. You can use the angle you obtained in blog 1 to ensure the solar panel is mounted at right angles to the incident sunlight, or you can use the default angle of 30°. The reason for the cut-outs is to reduce blockage to the airflow, to allow the boat to go faster.

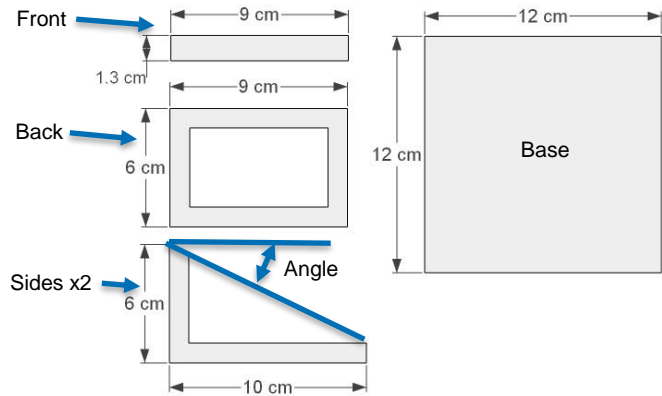

Step 6

Glue the motor stand to the back of the boat with the fan facing backwards. Balance the boat on the cylindrical pencil and try placing the stand with the solar panel mounted on it in different positions until the centre of gravity is slightly behind the centre of the boat. This is to stop the nose of the boat digging into the water as it goes along. Glue the stand onto the boat in this position, with the solar panel facing forwards. Glue the solar panel onto the stand so that it doesn't fall in the water. If you just glue it in a couple of places then it should be fairly easy to remove in order to complete the next module.

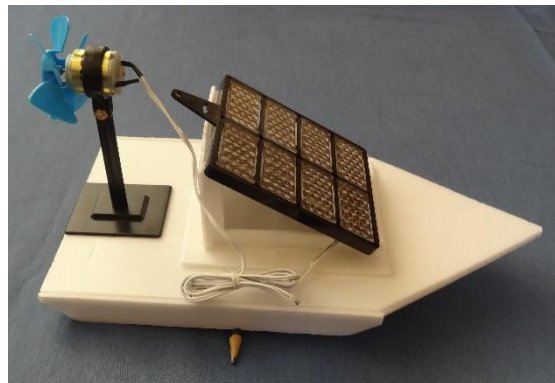

Step 7

Try the boat out in the water tray. It needs to be facing the sun to work correctly. If using a shallow plastic box then orientate the box so that the boat can run towards the sun. Glue the pompoms together to make a passenger and attach it to the boat, trying not to obstruct the light to the solar panel. You could make the passenger a sun-hat out of polystyrene foam offcuts.

